

The SFR 35 friction wheel drive

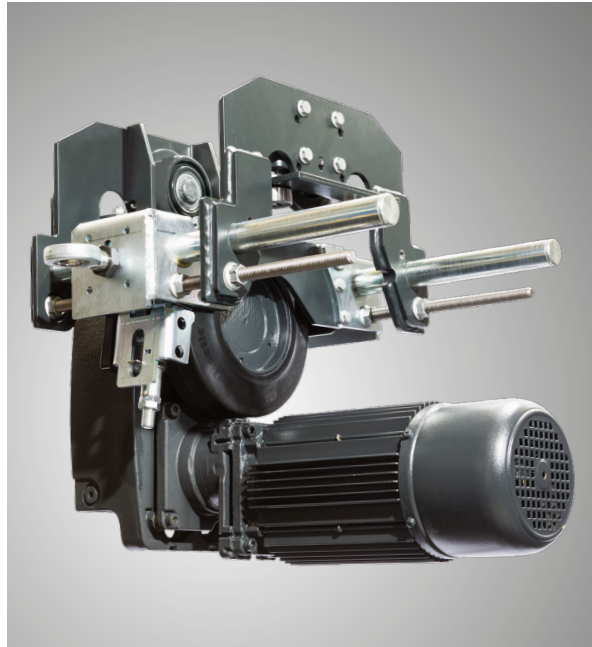
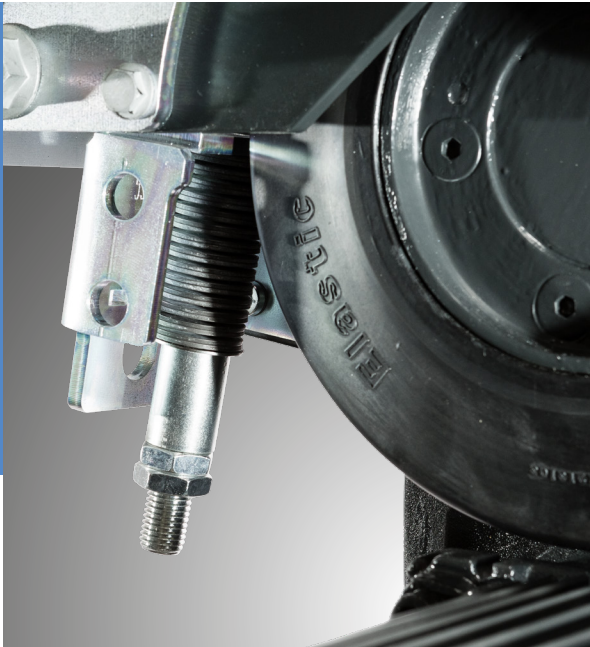

Your special requirements such as cam tracks, slight inclines or limited space situations require a special drive. This is exactly what the SFR 35 friction wheel drive from STAHL CraneSystems has been designed for. It is used as a maintenance-free drive for monorail carriages of rope and chain hoists and for suspension cranes.

Design

The torsion-resistant structure of the friction wheel drive is equipped with lifetime-lubricated, ball bearing-mounted wheels made from spheroidal graphite cast iron (GJS). A high friction coefficient and reliable transmission of the propulsive power are provided by the tread of the Rotafrix® (rubber friction ring with steel wire inlay) wheels, with their high quality and outstanding dynamic resistance. The well-trying travel drives from STAHL CraneSystems are used for propulsion. In this process, the friction wheel is pressed hard against the underside of the running rail using a pre-tensioned spring package. The wear-resistant friction wheels run smoothly and almost silently. They effectively absorb any shocks that occur.

Field of use

The SFR 35 friction wheel drive is designed for standard use inside buildings at ambient temperatures of -20°C to $+40^{\circ}\text{C}$. If you intend to use the equipment in other conditions, the engineers and technicians from STAHL CraneSystems would be pleased to deal with your inquiries.

The facts

- Maintenance-free drive for rope and chain hoists and suspension crane end carriages
- Also for use on cam tracks with a radius of 800 mm and above
- Ball bearing-mounted wheels and guide rollers made from spheroidal graphite cast iron with lifetime lubrication
- High-resistance tread made from Rotafrix® for good power transmission with low running noise
- Load-independent drive power transmission
- Travel carriage with wheel collapse support
- Drive motor with soft start-up and braking behaviour, rib cooling and ventilator
- Encapsulated flat brake
- Continuously adjustable for flange widths of 82–400 mm, with flange thicknesses of 7–27 mm
- Compact dimensions
- Can be retrofitted as a tractor for suspension cranes

The options

- Motor with external ventilation, temperature monitoring and motor heating
- Drive with protection class IP66
- Explosion-proof version for zone 1, zone 21, zone 2 and zone 22
- 4-pole drive for frequency inverters
- Drive limit switch
- Wheel arrester
- Other options on request

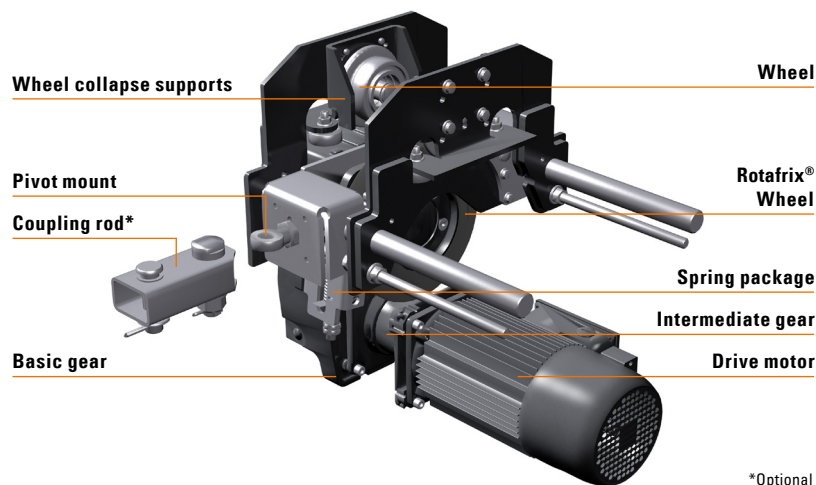

*Optional

Travel drive	Travel speed [m/min]	Travel loads [kg] with wheel diameter [mm]						Motor type	Nominal output with 50 Hz [kW]
		250	200	160	140	125	100		
SFR 35836123	12.5/3.2	17,000	15,600	14,100	13,200	12,400	11,000	8/2F12	0.37/0.09
SFR 35834133	16/4	19,500	18,100	16,400	15,400	14,600	13,000	8/2F13	0.55/0.13
SFR 35832133	20/5	13,700	12,800	11,700	11,000	10,500	9,400	8/2F13	0.55/0.13
SFR 35830133	25/6.3	12,100	11,300	10,300	9,700	9,200	8,300	8/2F13	0.55/0.13
SFR 35828133	32/8	8,200	7,700	7,200	6,800	6,500	5,900	8/2F13	0.55/0.13
SFR 35826133	40/10	6,600	6,300	5,800	5,500	5,300	4,800	8/2F13	0.55/0.13
SFR 35826313	40/10	12,900	12,200	11,300	10,800	10,300	9,400	8/2F31	1.25/0.32

This version is designed for standard use inside buildings. Ambient temperature –20 °C to +40 °C. Special ambient conditions on request. For information on travel drives with frequency inverters and explosion-proof drives, please see the latest product information.